

Hardware/Software Partitioning

Peter Marwedel
Informatik 12
TU Dortmund
Germany

2009/12/11



Structure of this course

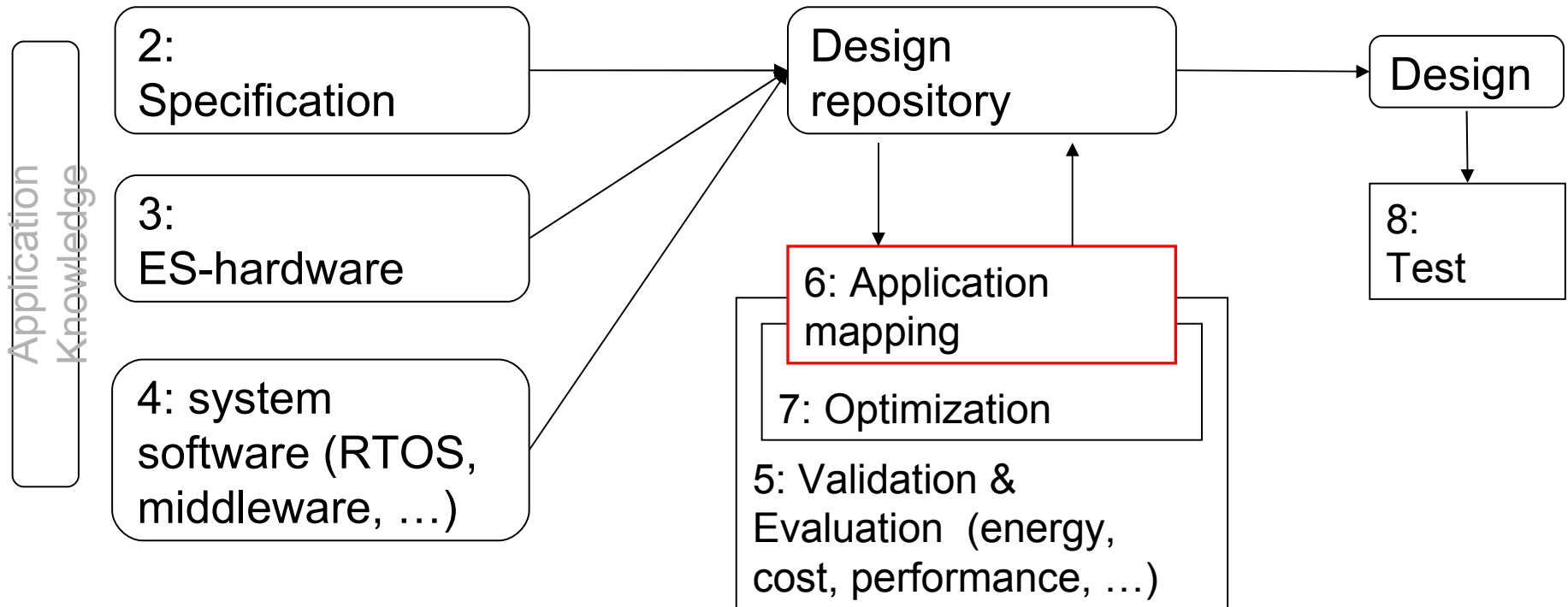

Numbers denote sequence of chapters

Hardware/software partitioning

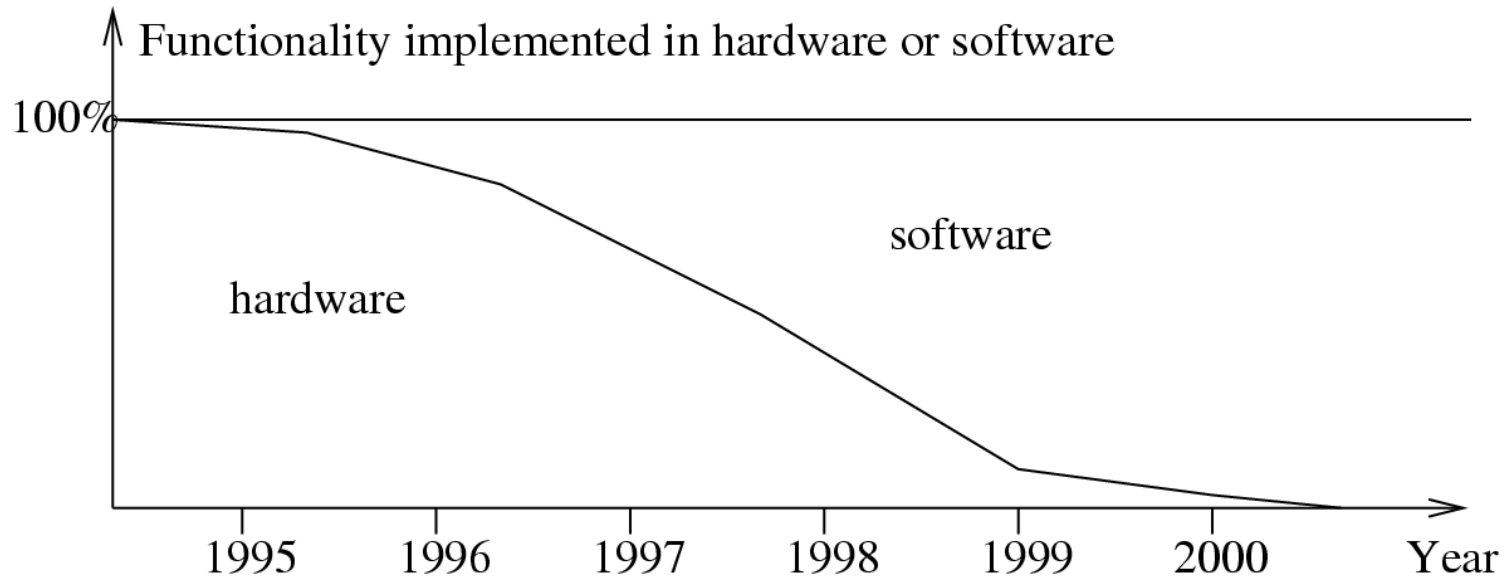

No need to consider special purpose hardware in the long run?
Correct for fixed functionality, but wrong in general, since
“By the time MPEG-n can be implemented in software, MPEG-n+1 has been invented” [de Man]

➡ Functionality to be implemented in software or in hardware?

Functionality to be implemented in software or in hardware?

Decision based on hardware/software partitioning, a special case of hardware/software codesign.

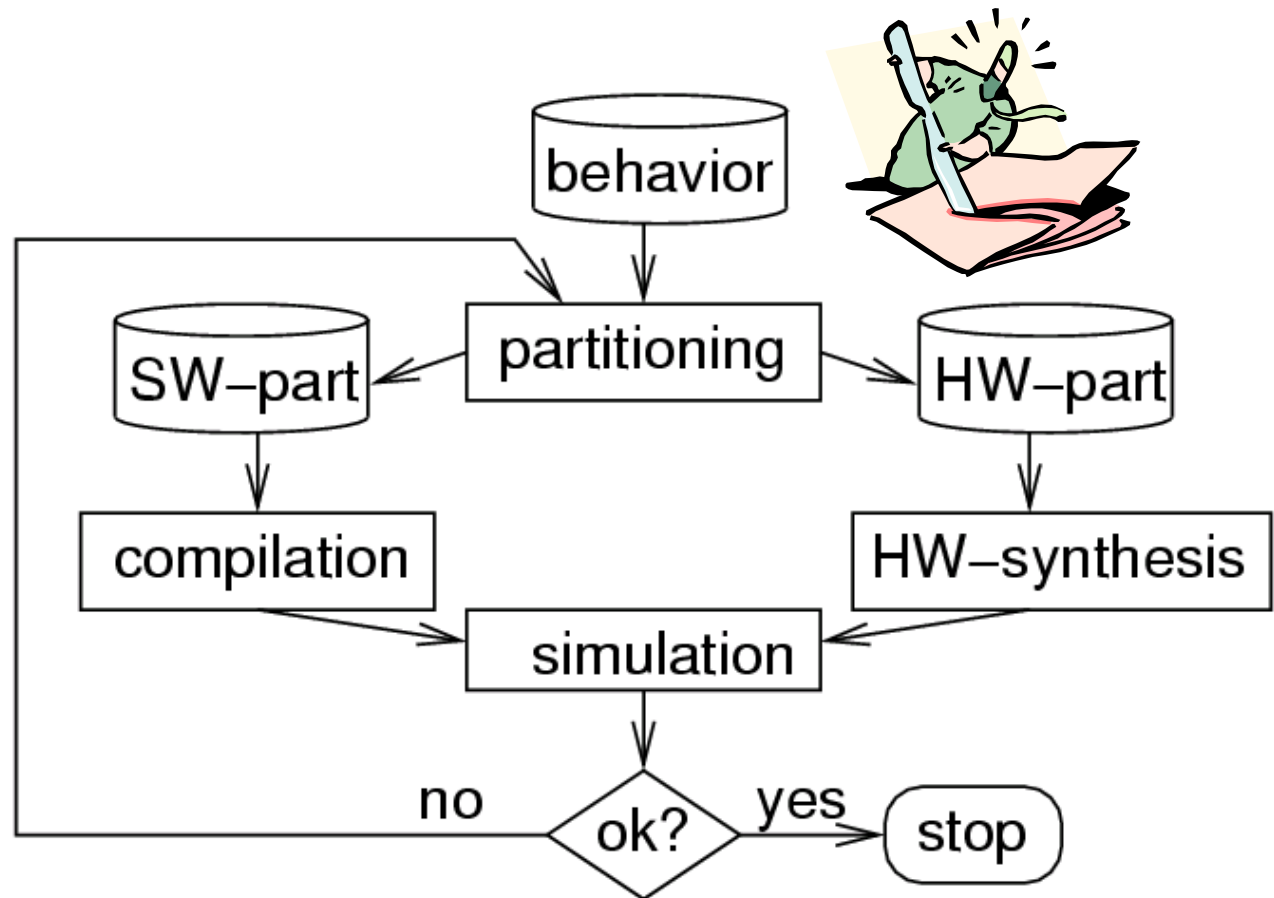

Codesign Tool (COOL) as an example of HW/SW partitioning

Inputs to COOL:

1. Target technology
2. Design constraints
3. Required behavior

Hardware/software codesign: approach

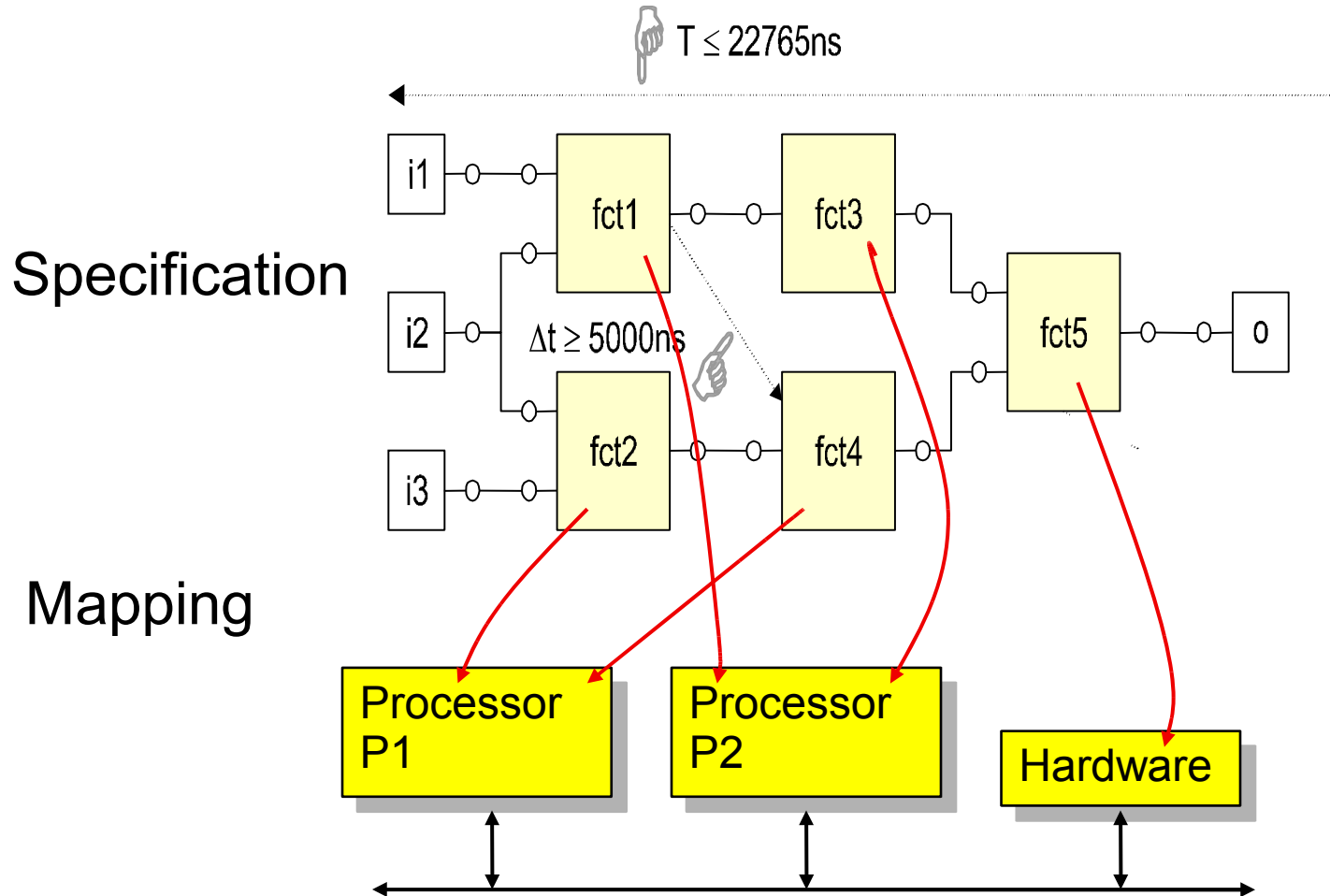

[Niemann, Hardware/Software Co-Design for Data Flow Dominated Embedded Systems, Kluwer Academic Publishers, 1998 (Comprehensive mathematical model)]

Steps of the COOL partitioning algorithm (1)

- 1. Translation of the behavior into an internal graph model**
- 2. Translation of the behavior of each node from VHDL into C**
- 3. Compilation**
 - All C programs compiled for the target processor,
 - Computation of the resulting program size,
 - estimation of the resulting execution time (simulation input data might be required)
- 1. Synthesis of hardware components:**

∇ leaf nodes, application-specific hardware is synthesized.
High-level synthesis sufficiently fast.

Steps of the COOL partitioning algorithm (2)

5. Flattening of the hierarchy:

- Granularity used by the designer is maintained.
- Cost and performance information added to the nodes.
- Precise information required for partitioning is pre-computed

5. Generating and solving a mathematical model of the optimization problem:

- Integer programming IP model for optimization.
Optimal with respect to the cost function (approximates communication time)

Steps of the COOL partitioning algorithm (3)

- 7. Iterative improvements:**
Adjacent nodes mapped to the same hardware component are now merged.

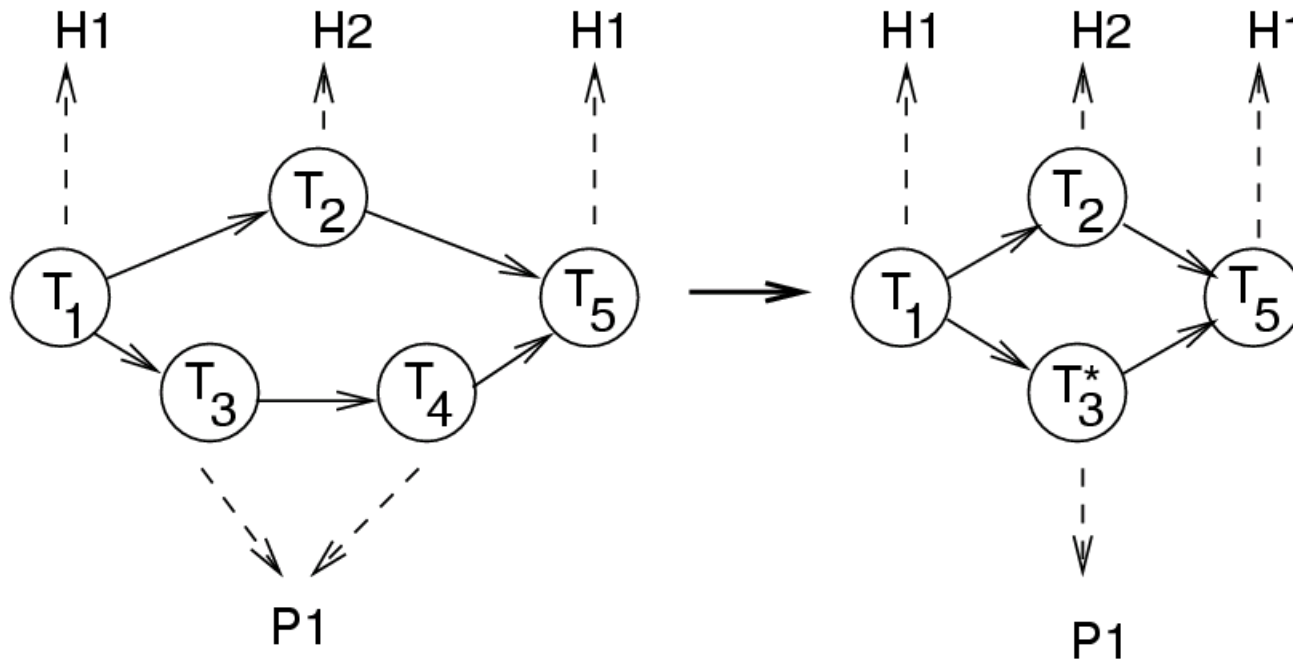

Steps of the COOL partitioning algorithm (4)

8. Interface synthesis:

After partitioning, the glue logic required for interfacing processors, application-specific hardware and memories is created.

An integer programming model for HW/SW partitioning

Notation:

- Index set I denotes task graph nodes.
- Index set L denotes task graph node **types**
e.g. square root, DCT or FFT
- Index set KH denotes hardware component **types**.
e.g. hardware components for the DCT or the FFT.
- Index set J of hardware component instances
- Index set KP denotes processors.
All processors are assumed to be of the same type

An IP model for HW/SW partitioning

- $X_{i,k}$: =1 if node v_i is mapped to hardware component type $k \in KH$ and 0 otherwise.
- $Y_{i,k}$: =1 if node v_i is mapped to processor $k \in KP$ and 0 otherwise.
- $NY_{\ell,k}$ =1 if at least one node of type ℓ is mapped to processor $k \in KP$ and 0 otherwise.
- T is a mapping from task graph nodes to their types:
 $T: I \rightarrow L$
- The cost function accumulates the cost of hardware units:

$$C = \text{cost}(\text{processors}) + \text{cost}(\text{memories}) + \text{cost}(\text{application specific hardware})$$

Constraints

Operation assignment constraints

$$\forall i \in I: \sum_{k \in KH} X_{i,k} + \sum_{k \in KP} Y_{i,k} = 1$$

All task graph nodes have to be mapped either in software or in hardware.

Variables are assumed to be integers.

Additional constraints to guarantee they are either 0 or 1:

$$\forall i \in I: \forall k \in KH: X_{i,k} \leq 1$$

$$\forall i \in I: \forall k \in KP: Y_{i,k} \leq 1$$

Operation assignment constraints (2)

$$\forall \ell \in L, \forall i: T(v_i) = c_\ell, \forall k \in KP : NY_{\ell,k} \geq Y_{i,k}$$

For all types ℓ of operations and for all nodes i of this type: if i is mapped to some processor k , then that processor must implement the functionality of ℓ .

Decision variables must also be 0/1 variables:

$$\forall \ell \in L, \forall k \in KP : NY_{\ell,k} \leq 1.$$

Resource & design constraints

- $\forall k \in KH$, the cost (area) used for components of that type is calculated as the sum of the costs of the components of that type. This cost should not exceed its maximum.
- $\forall k \in KP$, the cost for associated data storage area should not exceed its maximum.
- $\forall k \in KP$ the cost for storing instructions should not exceed its maximum.
- The total cost ($\sum_{k \in KH}$) of HW components should not exceed its maximum
- The total cost of data memories ($\sum_{k \in KP}$) should not exceed its maximum
- The total cost instruction memories ($\sum_{k \in KP}$) should not exceed its maximum

Scheduling

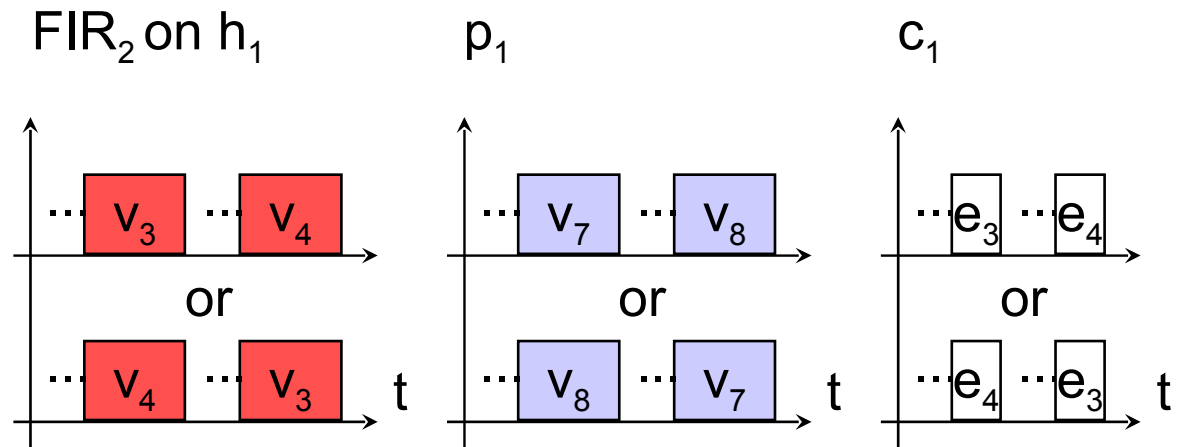
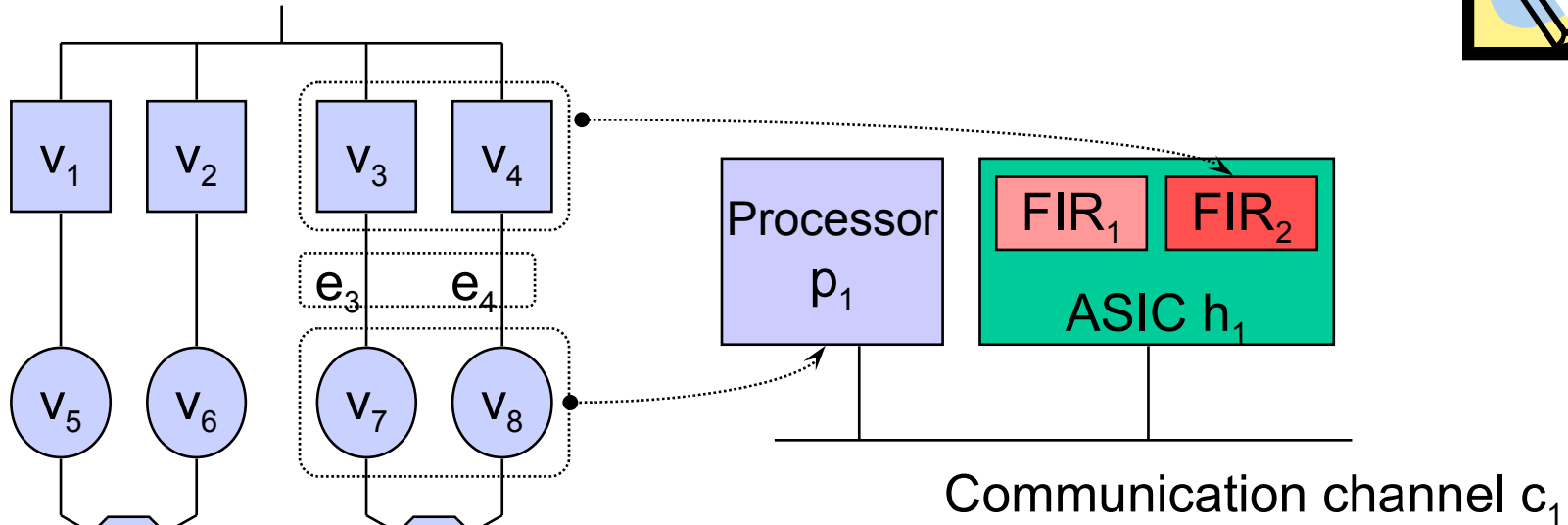
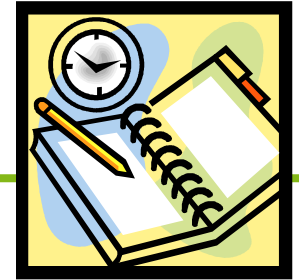

Scheduling / precedence constraints

- For all nodes v_{i_1} and v_{i_2} that are potentially mapped to the same processor or hardware component instance, introduce a binary decision variable b_{i_1,i_2} with $b_{i_1,i_2}=1$ if v_{i_1} is executed before v_{i_2} and $= 0$ otherwise.

Define constraints of the type

(end-time of v_{i_1}) \leq (start time of v_{i_2}) if $b_{i_1,i_2}=1$ and

(end-time of v_{i_2}) \leq (start time of v_{i_1}) if $b_{i_1,i_2}=0$

- Ensure that the schedule for executing operations is consistent with the precedence constraints in the task graph.
- Approach just fixes the order of execution and avoids the complexity of computing start times during optimization.

Other constraints

- **Timing constraints**

These constraints can be used to guarantee that certain time constraints are met.



- Some less important constraints omitted ..

Example

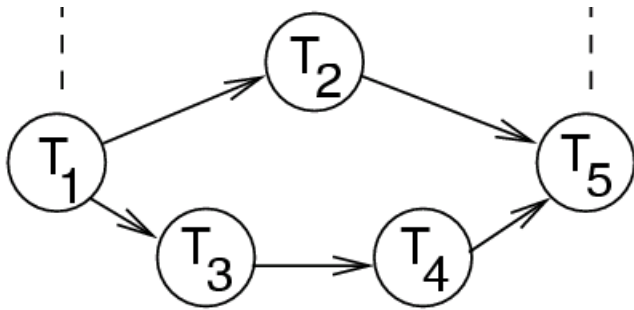

HW types H1, H2 and H3 with costs of 20, 25, and 30.

Processors of type P.

Tasks T1 to T5.

Execution times:

T	H1	H2	H3	P
1	20			100
2		20		100
3			12	10
4			12	10
5	20			100

Operation assignment constraints (1)

T	H1	H2	H3	P
1	20			100
2		20		100
3			12	10
4			12	10
5	20			100

$$\forall i \in I: \sum_{k \in KH} X_{i,k} + \sum_{k \in KP} Y_{i,k} = 1$$

$$X_{1,1} + Y_{1,1} = 1 \text{ (task 1 mapped to H1 or to P)}$$

$$X_{2,2} + Y_{2,1} = 1$$

$$X_{3,3} + Y_{3,1} = 1$$

$$X_{4,3} + Y_{4,1} = 1$$

$$X_{5,1} + Y_{5,1} = 1$$

Operation assignment constraints (2)

Assume types of tasks are $\ell = 1, 2, 3, 3,$ and 1 .

$$\forall \ell \in L, \forall i: T(v_i) = c_\ell, \forall k \in KP : NY_{\ell,k} \geq Y_{i,k}$$

$$NY_{1,1} \geq Y_{1,1}$$

$$NY_{2,1} \geq Y_{2,1}$$

$$NY_{3,1} \geq Y_{3,1}$$

$$NY_{3,1} \geq Y_{4,1}$$

$$NY_{1,1} \geq Y_{5,1}$$

Functionality 3 to be implemented on processor if node 4 is mapped to it.

Other equations

Time constraints leading to: Application specific hardware required for time constraints under 100 time units.

T	H1	H2	H3	P
1	20			100
2		20		100
3			12	10
4			12	10
5	20			100

Cost function:

$$C = 20 \#(H1) + 25 \#(H2) + 30 \#(H3) + \text{cost}(\text{processor}) + \text{cost}(\text{memory})$$

Result

For a time constraint of 100 time units and $\text{cost}(P) < \text{cost}(H3)$:

T	H1	H2	H3	P
1	20			100
2		20		100
3			12	10
4			12	10
5	20			100

Solution (educated guessing) :

T1 → H1

T2 → H2

T3 → P

T4 → P

T5 → H1

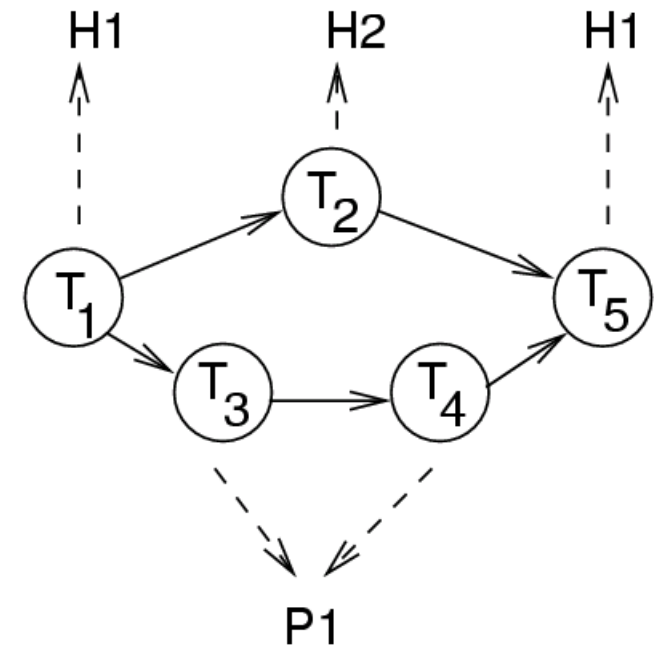

Separation of scheduling and partitioning

Combined scheduling/partitioning very complex;

- ➔ Heuristic: Compute estimated schedule
 - Perform partitioning for estimated schedule
 - Perform final scheduling
 - If final schedule does not meet time constraint, go to 1 using a reduced overall timing constraint.

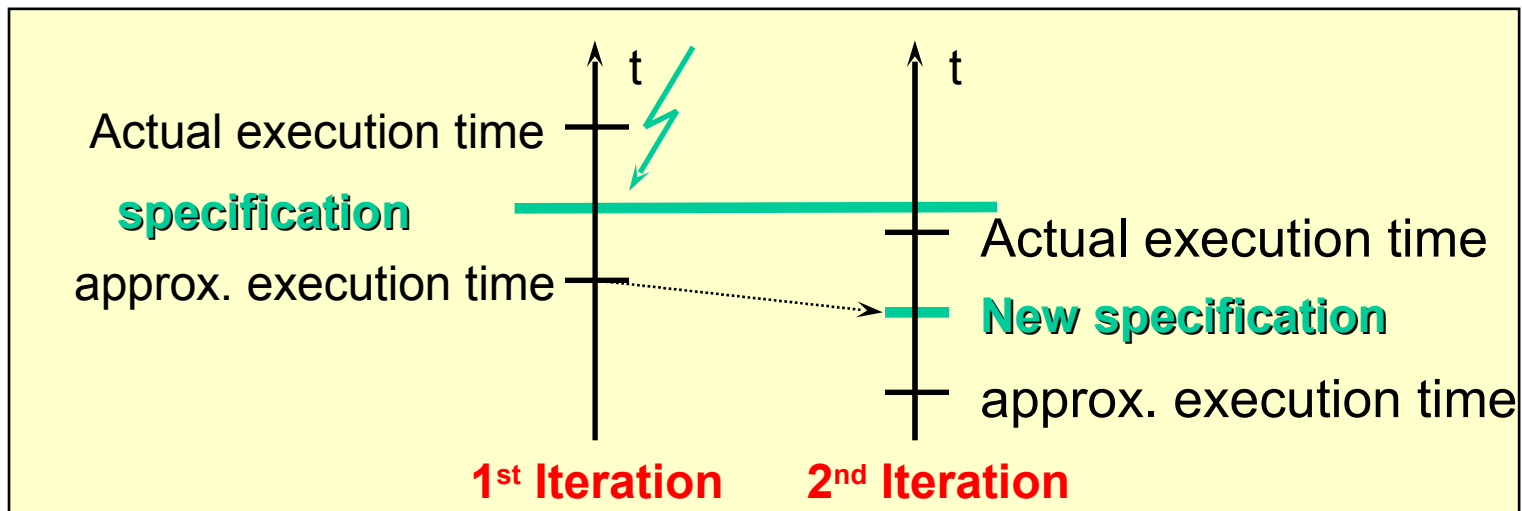

Application example

Audio lab (mixer, fader, echo, equalizer, balance units); slow SPARC processor
1 μ ASIC library
Allowable delay of 22.675 μ s (\sim 44.1 kHz)

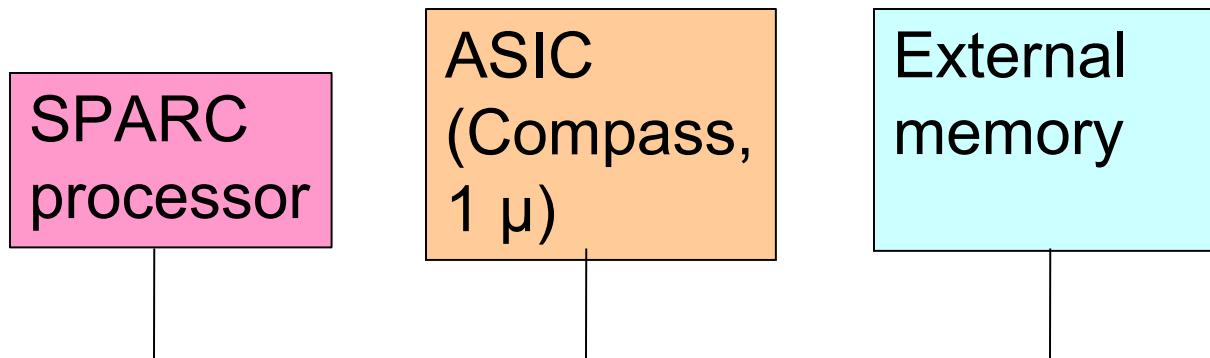

Outdated technology; just a proof of concept.

Running time for COOL optimization

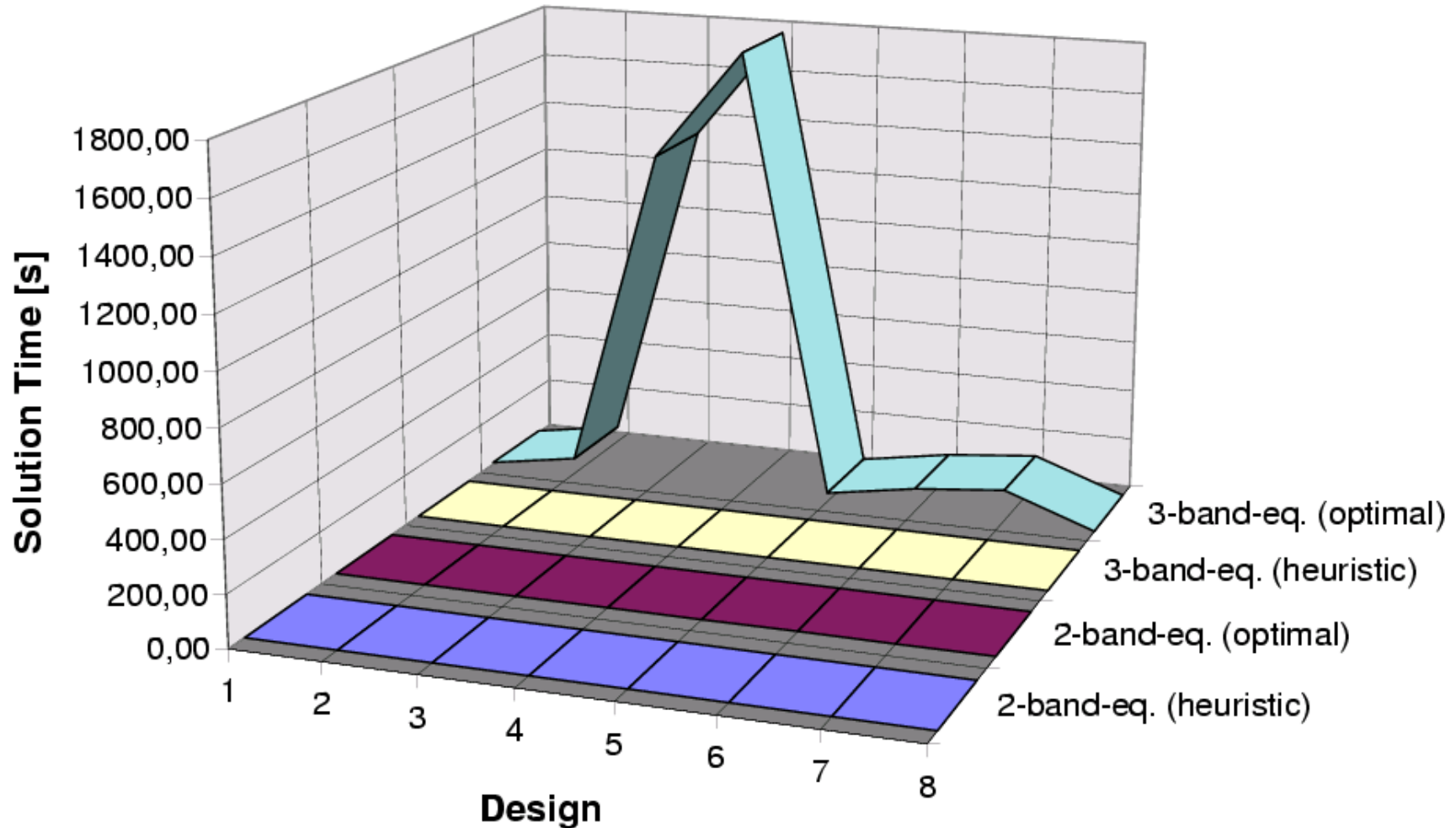

☞ Only simple models can be solved optimally.

Deviation from optimal design

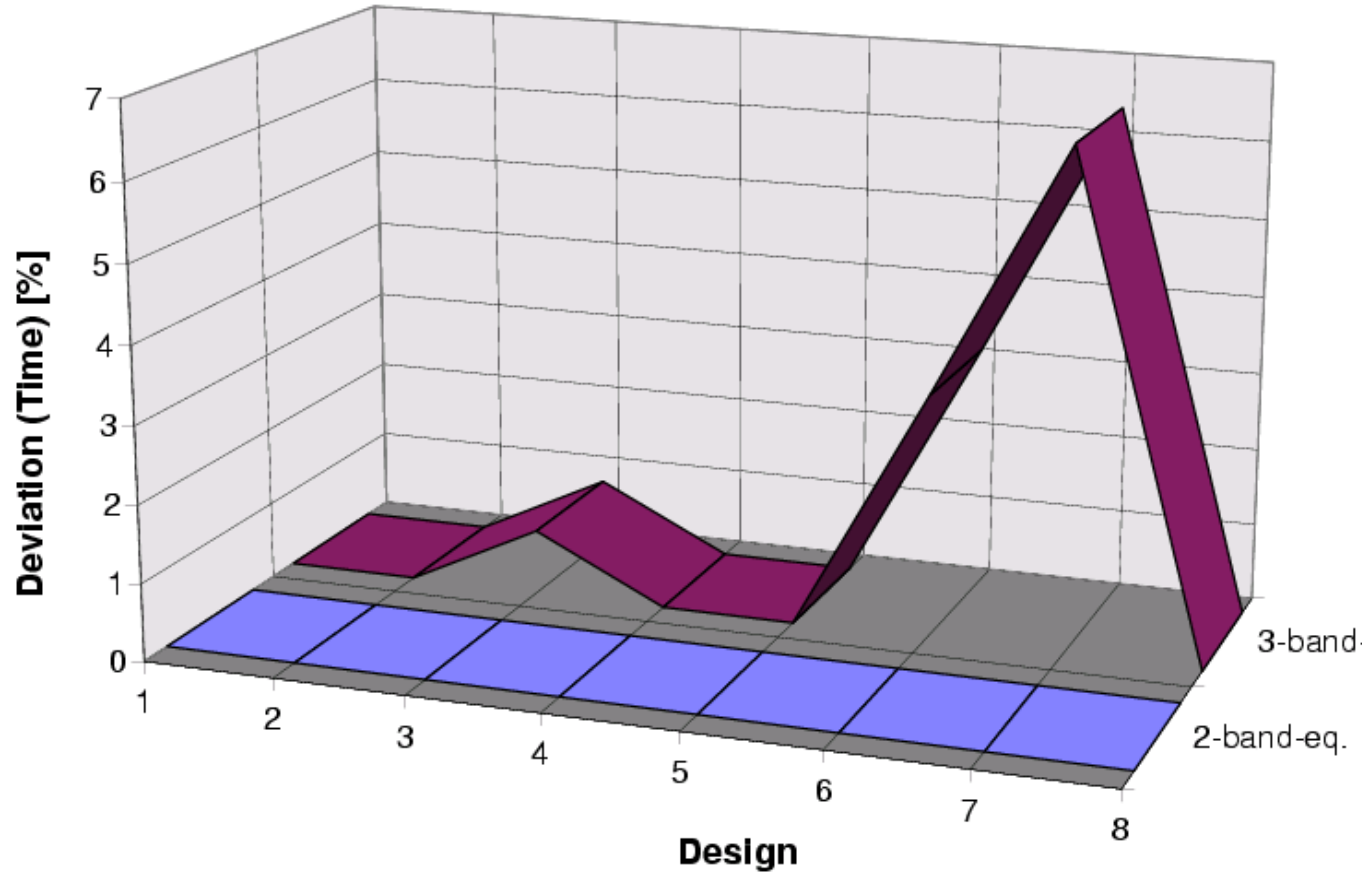

☞ Hardly any loss in design quality.

Running time for heuristic

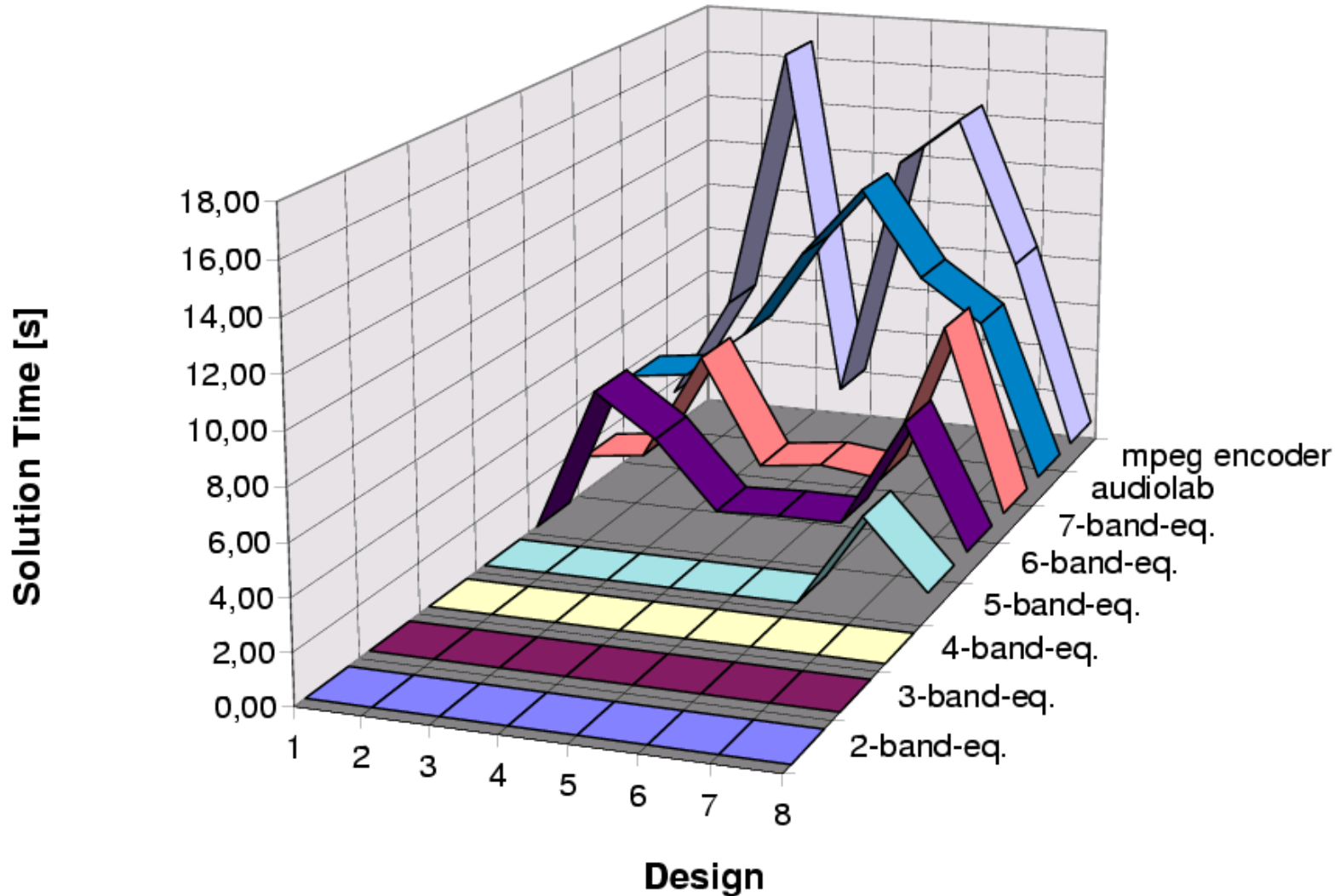

Design space for audio lab

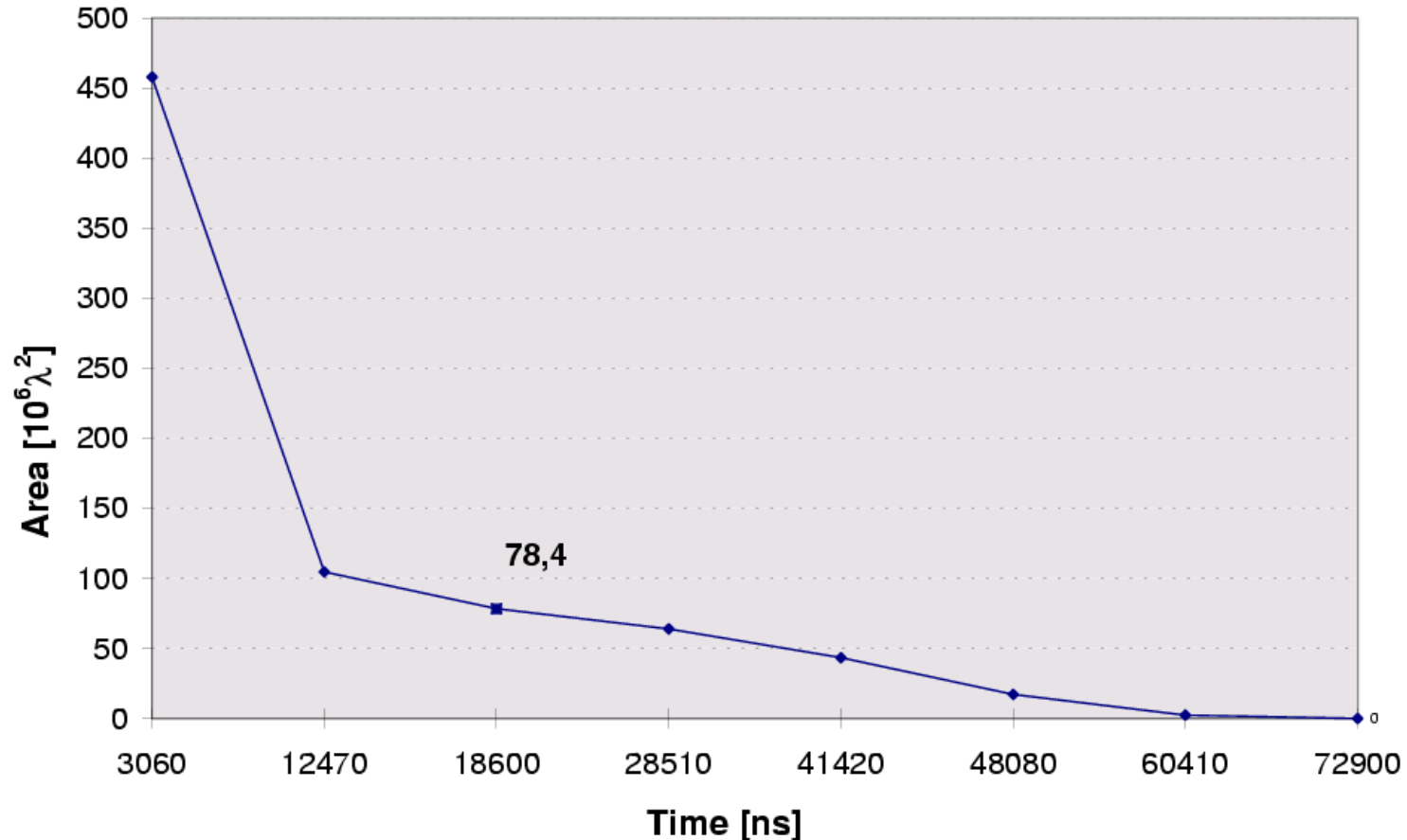

Everything in software: 72.9 μs, 0 λ²
Everything in hardware: 3.06 μs, 457.9x10⁶ λ²
Lowest cost for given sample rate: 18.6 μs, 78.4x10⁶ λ²,

Positioning of COOL

COOL approach:

- shows that formal model of hardware/SW codesign is beneficial; IP modeling can lead to useful implementation even if optimal result is available only for small designs.

Other approaches for HW/SW partitioning:

- starting with everything mapped to hardware; gradually moving to software as long as timing constraint is met.
- starting with everything mapped to software; gradually moving to hardware until timing constraint is met.
- Binary search.

HW/SW partitioning in the context of mapping applications to processors

- Handling of heterogeneous systems
- Handling of task dependencies
- Considers of communication (at least in COOL)
- Considers memory sizes etc (at least in COOL)
- For COOL: just homogeneous processors
- No link to scheduling theory