

Assignment 7

(10 Points)

Deadline is Monday, June 21, 2010, 16:00

7.1 A/D-Conversion (5 Points)

To convert an analog signal into its digital approximation, the conversion technique of *successive approximation* has been presented in the lecture. Convert the following analog inputs into their corresponding digital values using this technique: $U_{in} = 2.25V, 3.75V$ and $1.8V$. Specify for each input:

- the reference voltage U_{ref}
- the intermediate binary representation

at each point in time during the approximation cycles. The digital representation shall consist of a 4bit wide bit vector. The range of values shall be assumed to be $[U_{min}, U_{max}] = [1.0V, 4.75V] = [0000_2, 1111_2]$

7.2 FPGA structure (2 Points)

Given the following structure of a CLB block in an FPGA circuitry:

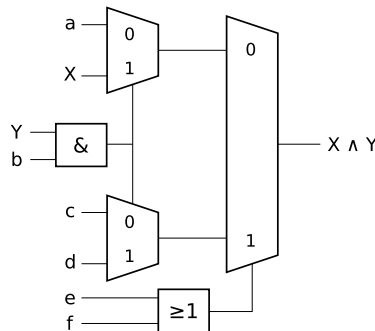

- For the given multiplexer-based CLB, specify appropriate input values so that the block realizes the boolean function $x \vee y$.
- Independently from this CLB, specify how the functions $x \wedge y$ and $\neg x$ can be realized with a single multiplexer.

7.3 CPU-Technologies (3 Points)

For the construction of embedded systems the use of (instruction) processors is predominant. In the lecture, different types of processors have been presented, such as *ASIC*, *DSP* or *VLIW*. Briefly list their characteristics regarding field of application, requirements and special characteristics of the instruction set and the memories.

General notes:

Dates and additional information can be found at <http://ls12-www.cs.tu-dortmund.de/en/teaching/courses/ss10/ies/>. The assignments will be published **Tuesdays** on a weekly basis and have to be solved until the next **Monday**. Drop your sheets into the mailbox in OH16 right across the secretariat (E22) or send an e-mail to your tutor. In the latter case, the submissions must be of either **PDF** or **PS** format. To pass the labs a minimum of 60% of the total points must be achieved.